

- Parmeter C08 > 6
- Parmeter C10 > 10
- Parmeter C11 > 70.0
- Parmeter C12 > 0.2
- Parmeter C13 > 0.2
- Parmeter CE1 > 5
- Parmeter>.....

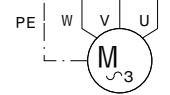

-3M3
Motor in driehoek!

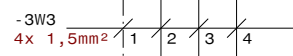
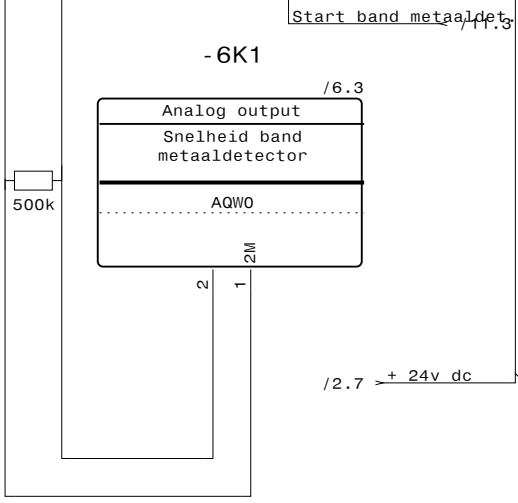
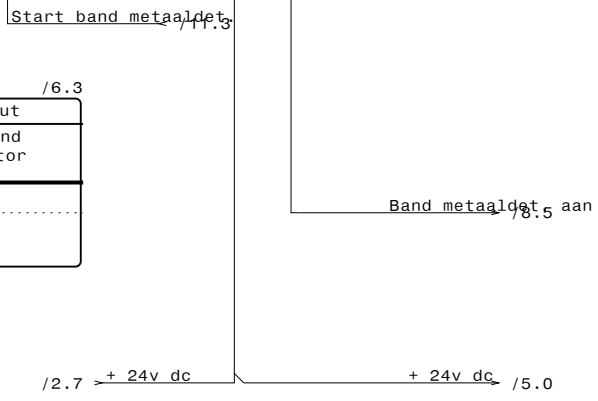

		Datum		23.03.2015	METAALDETECTIEBAND		Jaap Spek Mach.pr					
		Bew.		JS	Donders Engineering		Stadshaven 8 4285 AZ		FREQUENTIE REGELAAR METAALDET			
		Gecon.					Woudrichem				Blad 3	
Rev.	Wijziging	Datum	Naam	Norm					Projektblad: 5/22		van 15Bl.	

/5.9 =+ 24v dc
 /5.9 =0v

+ 24v dc /7.0
 0v - /7.0

/5.1 >24v display 0v display /11.0

-6K1

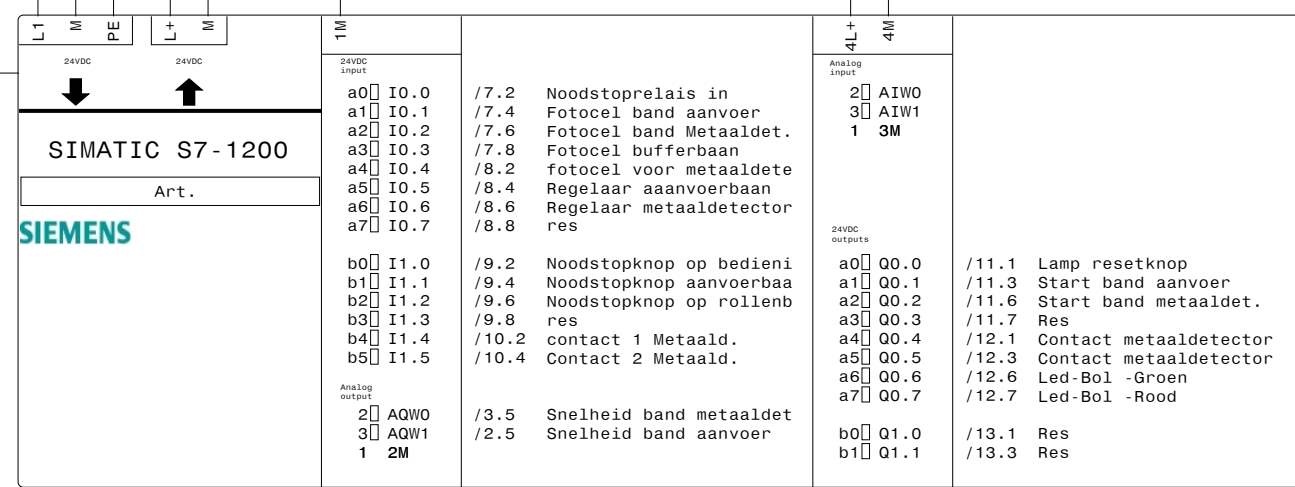
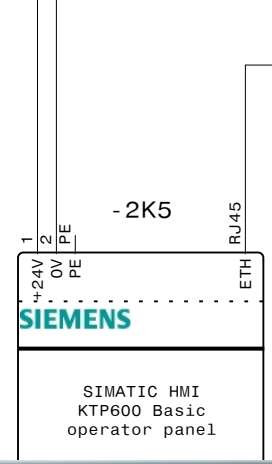

Datum	23.03.2015	METAALDETECTIEBAND Donders Engineering	Jaap Spek Mach.pr Stadshaven 8 4285 AZ Woudrichem	PLC OPSTELLING	=	
Bew.	JS				+	
Gecon.						
Rev.	Wijziging	Datum	Naam	Norm	Projektblad: 8/22	Blad 6 van 15Bl.

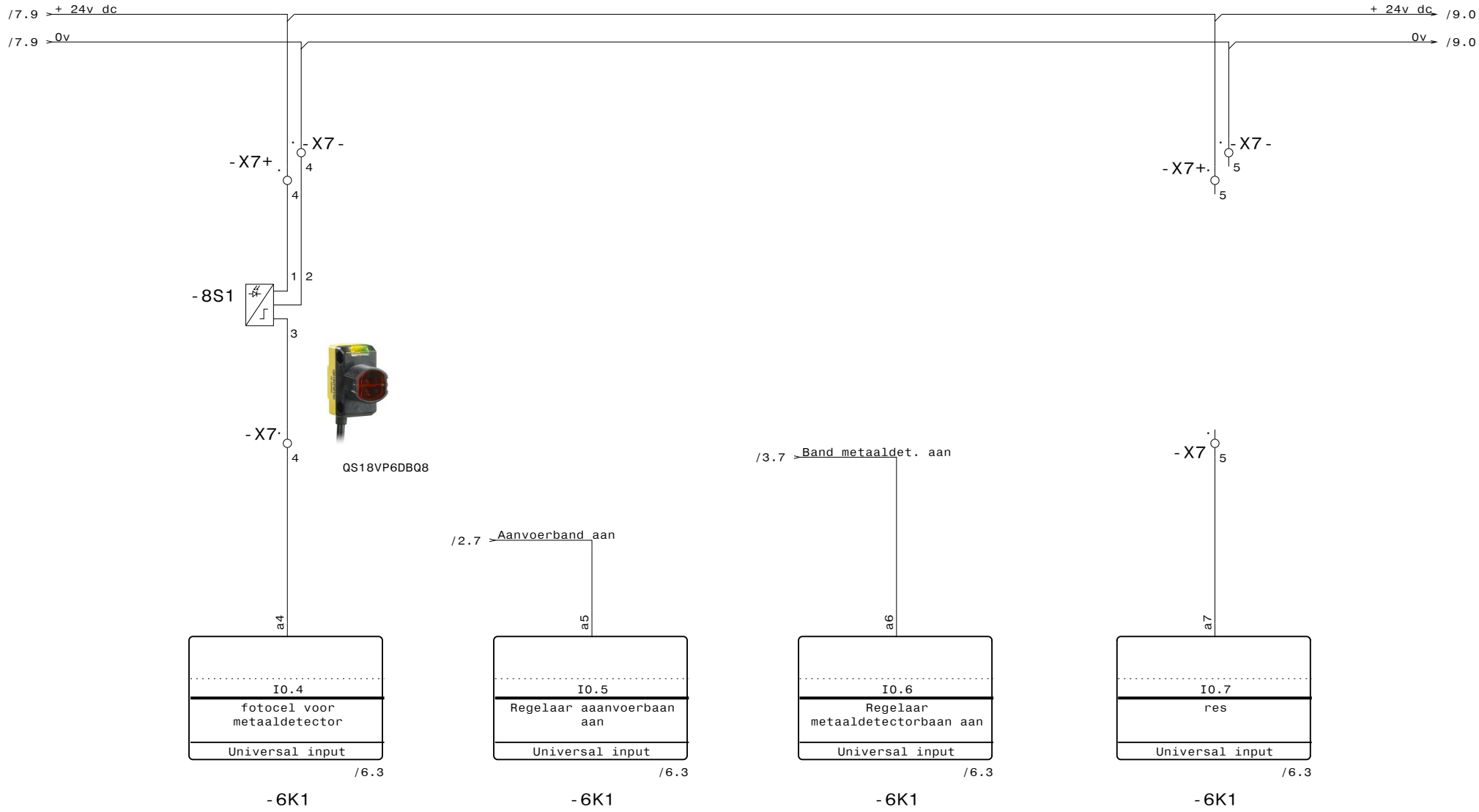

Rev.	Wijziging	Datum	Naam	Norm	Datum	23.03.2015	METAALDETECTIEBAND Donders Engineering	Jaap Spek Mach.pr Stadshaven 8 4285 AZ Woudrichem	INGANGEN E0.4 T.M. E0.7	=	
					Bew.	JS				+	
					Gecon.						Blad 8
								Projektblad: 10/22			van 15Bl.

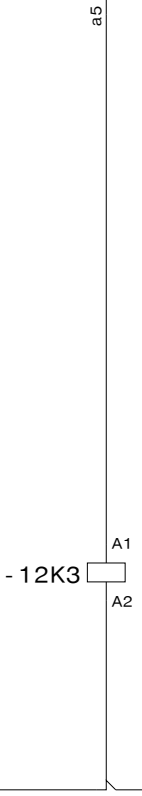
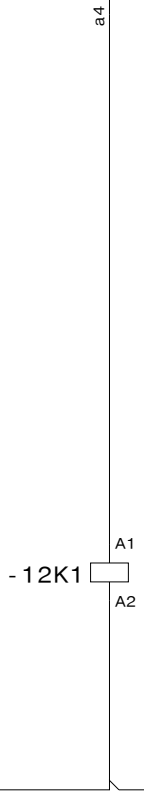
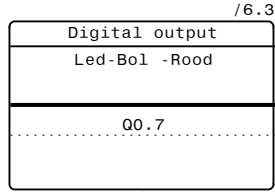
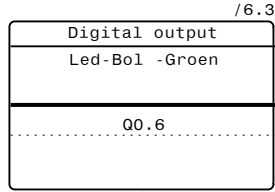
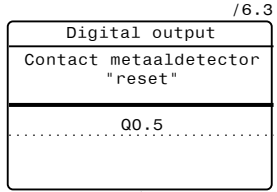
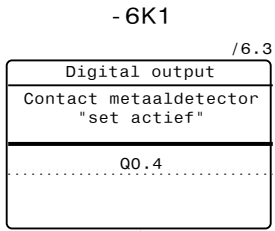

/15.4 $\frac{14}{12}$ 11

/15.6 $\frac{14}{12}$ 11

Rev.	Wijziging	Datum	Naam	Norm	Datum	23.03.2015	METAALDETECTIEBAND Donders Engineering	Jaap Spek Mach.pr Stadshaven 8 4285 AZ Woudrichem	UITGANGEN A0.4 T.M. A0.5	=	
					Bew.	JS				+	
					Gecon.						
Projektblad: 14/22										Blad 12 van 15Bl.	

0 1 2 3 4 5 6 7 8 9

A

A

B

B

C

C

D

D

E

E

F

F

				Datum	23.03.2015	METAALDETECTIEBAND	Jaap Spek Mach.pr			=
				Bew.	JS	Donders Engineering	Stadshaven 8 4285 AZ	RES		+
				Gecon.			Woudrichem			
Rev.	Wijziging	Datum	Naam	Norm				Projektblad:	16/22	Blad 14
										van 15Bl.

0 1 2 3 4 5 6 7 8 9

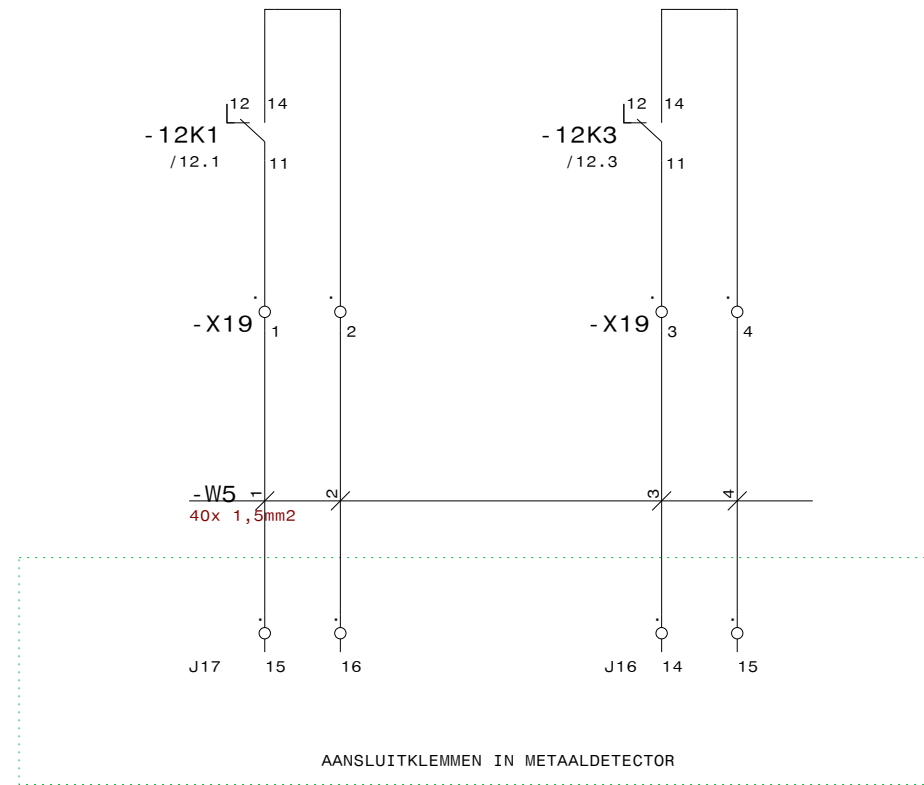

Rev.	Wijziging	Datum	Naam	Norm	Datum	23.03.2015	METAALDETECTIEBAND Donders Engineering	Jaap Spek Mach.pr Stadshaven 8 4285 AZ Woudrichem	COMMUNICATIE POT VRIJ	=	
						JS				+	
											Blad 15
									Projektblad: 17/22		van 15Bl.